



ErmaSmart #4

Cartesian Pick&Place XYZ

System for placing pots/vials in trays and parts on boxes/pallets

Description of the system

The XYZ Cartesian Pick&Place system is an **automated system** for **packing pots/vials** into **trays** or placing parts on **boxes/pallets**. It incorporates a **3 axis XYZ Cartesian system** that is often used in industrial packaging and assembly operations. The functions and components are derived from real industrial components used in the food, pharmaceutical or cosmetic industry (jars/vials) or the assembly industry (boxes/pallets).

This XYZ Cartesian Pick&Place system (ref XY10) designed in the spirit of **the industry of the future** (Industry 4.0) meets the main requirements on intelligence and the evolution of production methods:

- ✓ **Flexibility & Customisation** with the possibility of packaging customised items to the customer's order
- ✓ **IoT & Communications** with the writing of RFID tags for the identification and tracking of customer order packages.

This **automated** system can be **used as a stand-alone system** with jars/flasks or cans/pallets, but can also be **integrated into the flexible ErmaSmart production line** (see pages 3 and 4).

The main functions of the XYZ Cartesian Pick&Place are :

- ✓ **Convey** the finished items (pots/vials or reducer bases) from the entrance to the packaging station
- ✓ In **"Packaging" configuration: Place** the trays under the packaging station - Package the jars/vials in the trays to form a package
- ✓ In the **"Assembly" configuration: Place** the boxes/pallets under the packaging station - Place the gearbox bases in the boxes/pallets
- ✓ **Dispose of** trays or boxes/pallets
- ✓ **Write** information on RFID tags on trays and boxes/pallets for traceability

This training system is mainly intended for **activities in the fields of operation, system control, industrial maintenance, electrical engineering, automation and mechanics**.

This product is accompanied by a technical and educational file in digital format.

Highlights

- Real **industrial system** with **modern technologies** (XYZ Cartesian Pick&Place, IO-Link, Ethernet, RFID...)
- **Production flexibility** with the packaging of different containers in different packages (pots/vials in trays) or the placement of parts (gearbox bases) on boxes/pallets
- **Traceability of the customer's order** with the writing of RFID tags
- System usable in the fields of **electrical engineering, industrial maintenance, and the operation and control of automated systems**
- Includes Siemens Tia Portal programming software for programming the PLC and the dialogue terminal
- **IO-Link technology** with IO-Link Profinet master (IFM brand) and LR Device sensor monitoring/parameterisation software and IO-Link intelligent sensors (RFID, vacuum generator, photoelectric sensor)
- Possible extensions to the ErmaSmart flexible production line

CAP CIP - Bac PRO PLP / MELEC / MSPC
BTS CRSA / Electrical engineering / MS
IUT - Universities - Engineering schools

Main Themes

Industrial Maintenance
Production Control
Multi-technology Systems Design
Electrical Engineering and Automation

Themes
"Industry 4.0"
addressed

Scalability & Flexibility

Customisation

Simplified programming

Digital twin

Mobile Robotics

Collaborative Robotics

Efficient Actuators

CAPM & CMMS

Digital instructions & MES

Quality control "online".

Vision & Smart Sensors

IOT & Communications

Big Data, AI & Predictive Maintenance

Augmented reality

Virtual reality

Additive manufacturing for tooling...

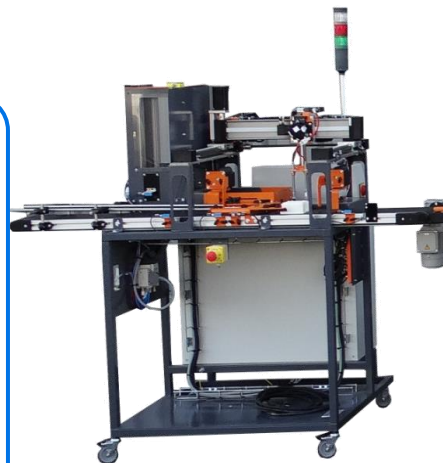



General

The XYZ Cartesian Pick&Place (Ref: XY10) consists mainly of :

- ✓ A welded frame with epoxy paint on 4 castors with brakes and a tray for storing products
- ✓ An electrical cabinet with a man-machine interface (colour touch panel) fixed to the chassis
- ✓ An operating part with two main functional assemblies, the conveyor and the XYZ Cartesian Pick&Place
- ✓ Protective elements only for the so-called "dangerous" areas in order to give priority to the accessibility and visualization of the various components

Functional sub-assembly "Gripping and placing".

It is used to tray jars/flasks and place the reducer bases in the boxes/pallets.

It consists mainly of :

- ✓ A jar/flask jogging cylinder and gearbox bases at Conveyor Station 1
- ✓ A rack for inserting trays and boxes/pallets into the vertical magazine
- ✓ A vacuum gripping tool with suitable tools for gripping jars/vials and reducer bases (IO-Link vacuum generator with energy saving)

Functional sub-assembly "Conveyor"

It consists mainly of :

- ✓ A 9 m/min belt conveyor with edges
- ✓ A 230/400V 0.09 kW three-phase asynchronous geared motor controlled by a variable speed drive
- ✓ An arrival station for pots/vials or reducer bases with presence detector (Station 1)
- ✓ A packaging station with jogging cylinder and tray or box/pallet presence detector (Station 2)
- ✓ An evacuation zone

Functional sub-assembly "XYZ robot"

It consists mainly of :

- ✓ A vertical gravitational magazine for trays ("Packaging" configuration) or "Boxes/Pallets" ("Assembly" configuration) with dispensing cylinder and low level sensor (IO-Link photoelectric sensor with on-board intelligent task)
- ✓ A three-axis XYZ Cartesian robot with stepper motor incorporating an encoder, belt drive (XY axis), rack drive (Z axis) and greaseless linear guidance. The working area is approximately 500 x 500 x 100 mm with a load capacity of 10N
- ✓ Limit switches on all three axes
- ✓ A suction cup gripping mechanism with vacuum switch

Electrical control / command cabinet

It consists mainly of :

- ✓ A padlockable disconnect switch
- ✓ A set of electrical protections
- ✓ A safety relay, an emergency stop button and a system reset button
- ✓ A Siemens S7-1200 PLC (or optional S7-1500)
- ✓ A Siemens SIMATIC HMI KTP700 Basic (7 inch) colour touch screen Human Machine Interface
- ✓ A switch to ensure communication between the PLC, the HMI and the connected environments
- ✓ An IO-Link Profinet master (IFM brand) and MONEO Configure sensor visualization and setting software
- ✓ A variable speed drive for the conveyor
- ✓ Three axis control boards for the stepper motors of the three XYZ axes
- ✓ An IO-Link RFID transceiver to write traceability information on RFID tags stuck on trays and boxes/pallets
- ✓ An area dedicated to the electrical wiring of new components in the context of system improvements (new sensors, actuators, etc.)

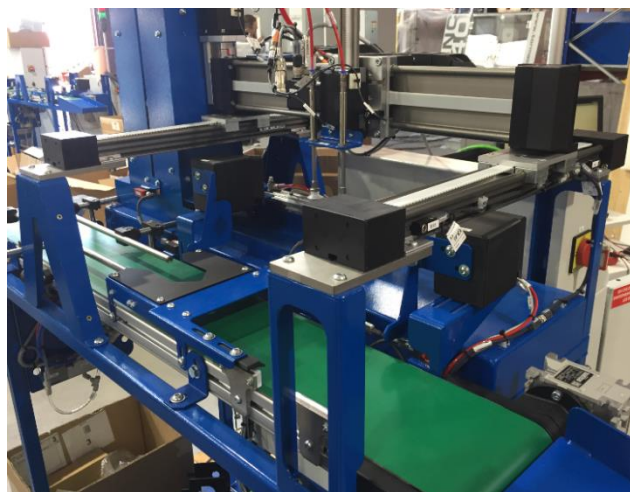

3-axis Cartesian robot



IO-Link Master and LR Device monitoring and parameterisation software



Programmable Logic Controller Industrial S7-1200



Human Machine Interface Siemens HMI KTP700 Basic

Installation features

XY10 :

- ✓ Dimensions (LWD): 1800 x 890 x 1720 mm
- ✓ Mass: 200 kg
- ✓ Power supply: 230 V three-phase (P + N + T)
- ✓ Pneumatic supply: 7 bar



Digital Twin (Ref: JN-VUPro-XY10)

The XYZ digital Cartesian Pick&Place system twin is developed in the VIRTUAL UNIVERSE Pro environment

The strengths of the solution :

- ✓ Possibility of creating or modifying 3D models from the software's library or from an import from the main CAD software: Solidworks, Inventor, Catia and also the main 3D file formats: 3DXML, 3DS, OBJ, etc...
- ✓ Real-time model simulation
- ✓ Control identical to the real system using the simulated console in TIA portal (it is also possible to use a real console)
- ✓ Execution of the PLC program identical to the real system by using a real PLC
- ✓ Modification of a program as on the real machine using the SIEMENS TIA portal PLC programming software
- ✓ Connection to the PLC in the V126 reference (in addition to the machine PLC) to operate the Digital Twin
- ✓ Ability to create faults on any sensor or actuator
- ✓ Use on PC or virtual reality headset
- ✓ Fully open and modifiable simulation (e.g. changing the position of the sensors, adding an actuator or sensor)
- ✓ Possible creation of own simulations
- ✓ Interactive simulations, where the user can pick up and move objects in the 3D world

The main uses of a digital twin are :

- ✓ Training of production operators
- ✓ Pre-study / design of automated systems
- ✓ Machine programming before or during manufacture
- ✓ Remote program modification and or mechanical modification (without access to the actual machine)
- ✓ The modification of a program and or mechanical modification followed by functional testing of the modification while avoiding system degradation due to an error
- ✓ Modification of a program and or mechanical modification while limiting production downtime

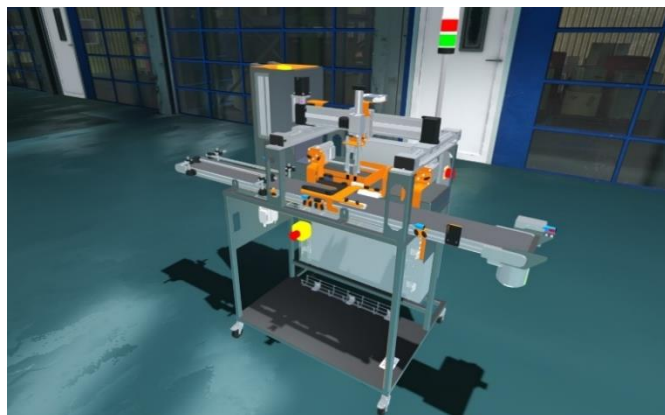

References:

VI20 :

Virtual UniversePro: Simulation of systems in a 3D environment - 1 license (Can be used on the VI06/VI07 virtual reality headset or on a regular PC)

VI22 :

Virtual UniversePro: Simulation of systems in a 3D environment - Establishment license (Can be used on the VI06/VI10 virtual reality headset or on a regular PC)

VI26 :

3D programmable digital twin Cartesian Robot XYZ on Virtual Universe Pro, with Siemens S7-1200 PLC package and I/O board (VU Pro license to be purchased separately)

Mechanical module Cartesian axes XYZ (Ref: XY14)

This sub-system is a **mechanical sub-system** allowing :

- ✓ The adjustment of the flatness of the axes
- ✓ Parallelism/perpendicularity adjustment of the axes
- ✓ Belt tension adjustment
- ✓ The study of the influence of the settings on the necessary motor torque
- ✓ The study of the influence of the on-board mass on the necessary engine torque
- ✓ The study of the influence of the cables/types of cables present in the cable chains on the necessary motor torque

It consists mainly of :

- ✓ A three-axis XYZ Cartesian axis system with stepper motor incorporating an encoder, belt drive (XY axis), rack drive (Z axis) and greaseless linear guidance. The working area is approximately 500 x 500 x 100 mm with a load capacity of 10N
- ✓ An electronic dynamometer to measure the forces required to set the axes in motion
- ✓ A belt tension control instrument
- ✓ A precision spirit level
- ✓ A 500mm ruler

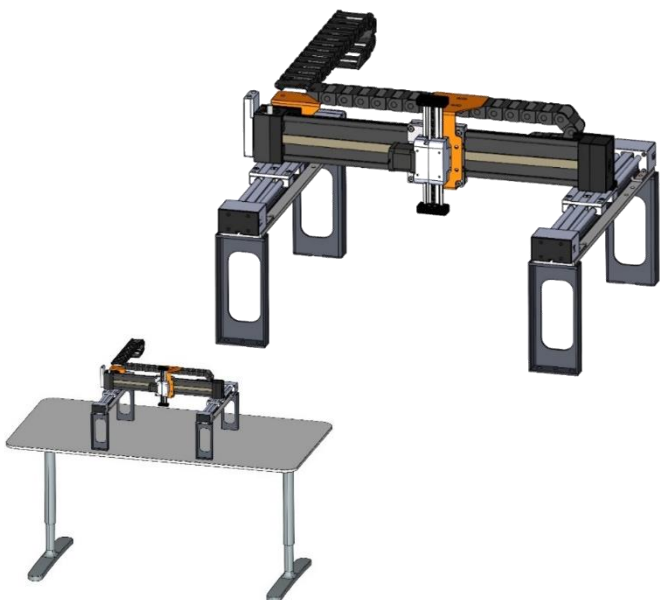

Cartesian Pick&Place XYZ

Station 4 of the ErmaSmart flexible production line "Packaging"

ErmaSmart Station 4

In the ErmaSmart "Packaging" context, the Cartesian XYZ Pick&Place is used to ensure the placement of jars/vials in trays.

Upstream of the Cartesian Pick&Place XYZ, are:

- Station 1: The **2D Unscrambling & Screwing Robot**, 2D/3D jar/flask unscrambling and conveyor placement system (ref **ON10** and associated codes)
- Item 2: The **Dosaxe**, automatic linear axis filling system (ref **DX10** and associated codes)
- Station 3: The **Collaborative Capping & Assembly Robot**, capping system, custom overcapping and control (ref **MI00** and associated codes)

Downstream of the Cartesian Pick&Place XYZ, are:

- Item 5: The **Dynamic Vertical Store** (ref **VL10** and associated codes)
- Station 6: The **manual order picking, packing and palletising station with RFID tracking** (ref **PM91**).

ErmaSmart Configuration "Conditioning"

In the ErmaSmart "Packaging" configuration, the Cartesian XYZ Pick&Place provides:

- Conveying the jars/vials to the packaging station
- The deposit of trays under the packaging station
- Putting the jars/flasks in the trays
- Placing the gearbox bases in the boxes/pallets
- The inscription of information on the RFID tags of the boxes/pallets
- Discharge of the boxes/pallets onto the conveyor belt to the next station.

This configuration requires the code:

- XY10: Cartesian Pick&Place XYZ

Dynamic Vertical Warehouse integrated into the ErmaSmart Industry 4.0 Factory "Packaging"

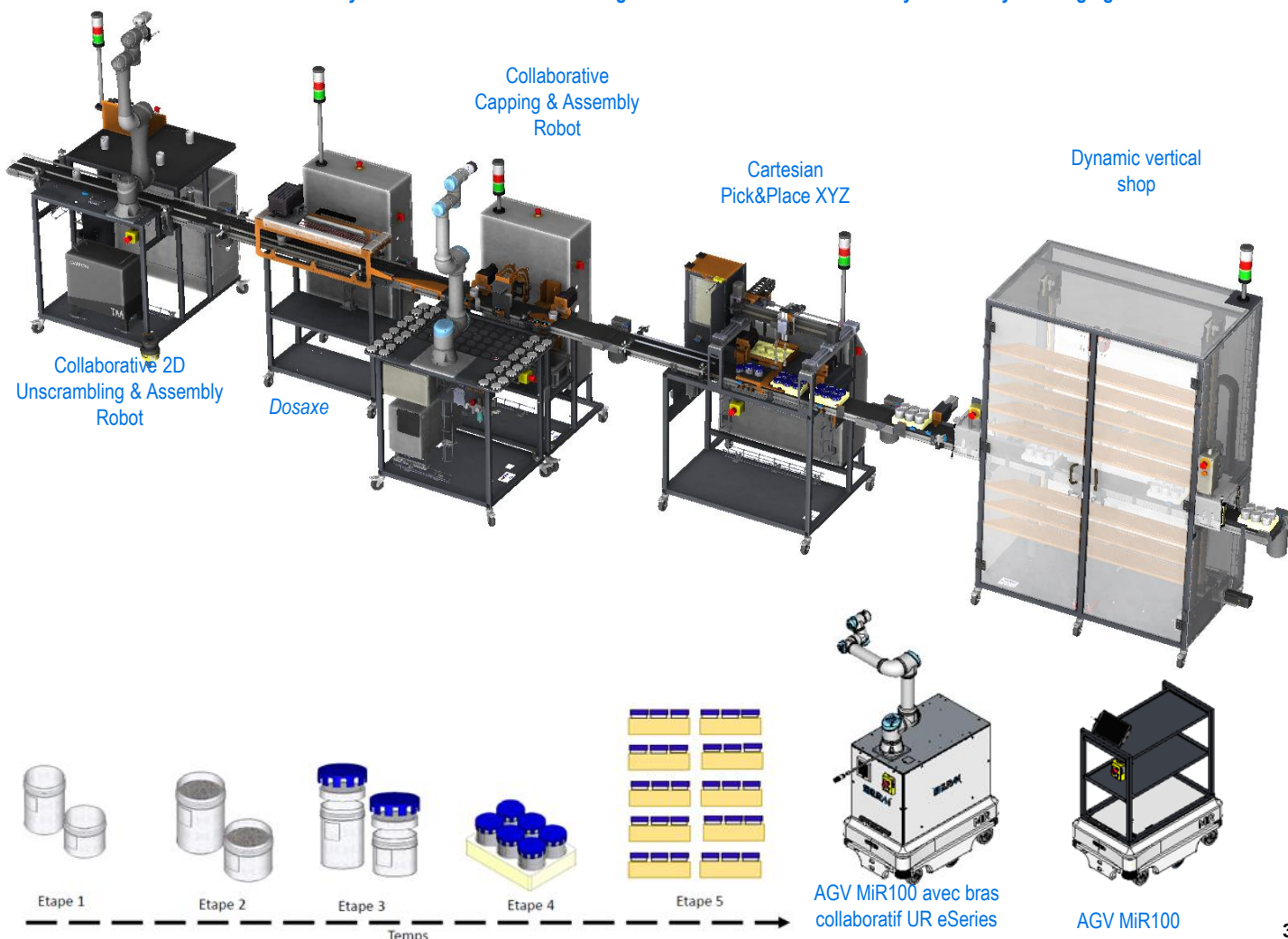

Cartesian Pick&Place XYZ

Station 1 of the ErmaSmart flexible production line "Assembly"

ErmaSmart Station 1 "Assembly"

In the ErmaSmart "Packaging" context, the Cartesian XYZ Pick&Place is used for the placement of gearbox bases in boxes/pallets and the RFID identification of boxes/pallets.

Downstream of the Dynamic Vertical Store are:

- Station 2: **The Collaborative Capping & Assembly Robot**, customised assembly system and control (ref MI00 and associated codes)
- Station 3: **The 2D Unscrambling & Screw Assembly Collaborative Robot** (ref ON10 and associated codes)
- Item 4: **The Dynamic Vertical Store** (ref VL10 and associated codes)
- Station 5: **The manual order picking, packing and palletising station with RFID tracking** (ref PM91).

ErmaSmart Configuration "Assembly"

In the ErmaSmart "Assembly" configuration, the Cartesian XYZ Pick&Place is the key:

- Conveying the gearbox bases close to the packaging station
- The deposit of boxes/pallets under the packaging station
- Placing the gearbox bases in the boxes/pallets
- The inscription of information on the RFID tags of the boxes/pallets
- Discharge of the boxes/pallets onto the conveyor belt to the next station.

This configuration requires the code:

- XY10: XYZ Cartesian Pick&Place with RFID tracking
- XY12: Tools and components for the XYZ Cartesian Pick&Place assembly process

XYZ Cartesian Pick&Place integrated into the ErmaSmart Industry 4.0 Factory "Assembly"

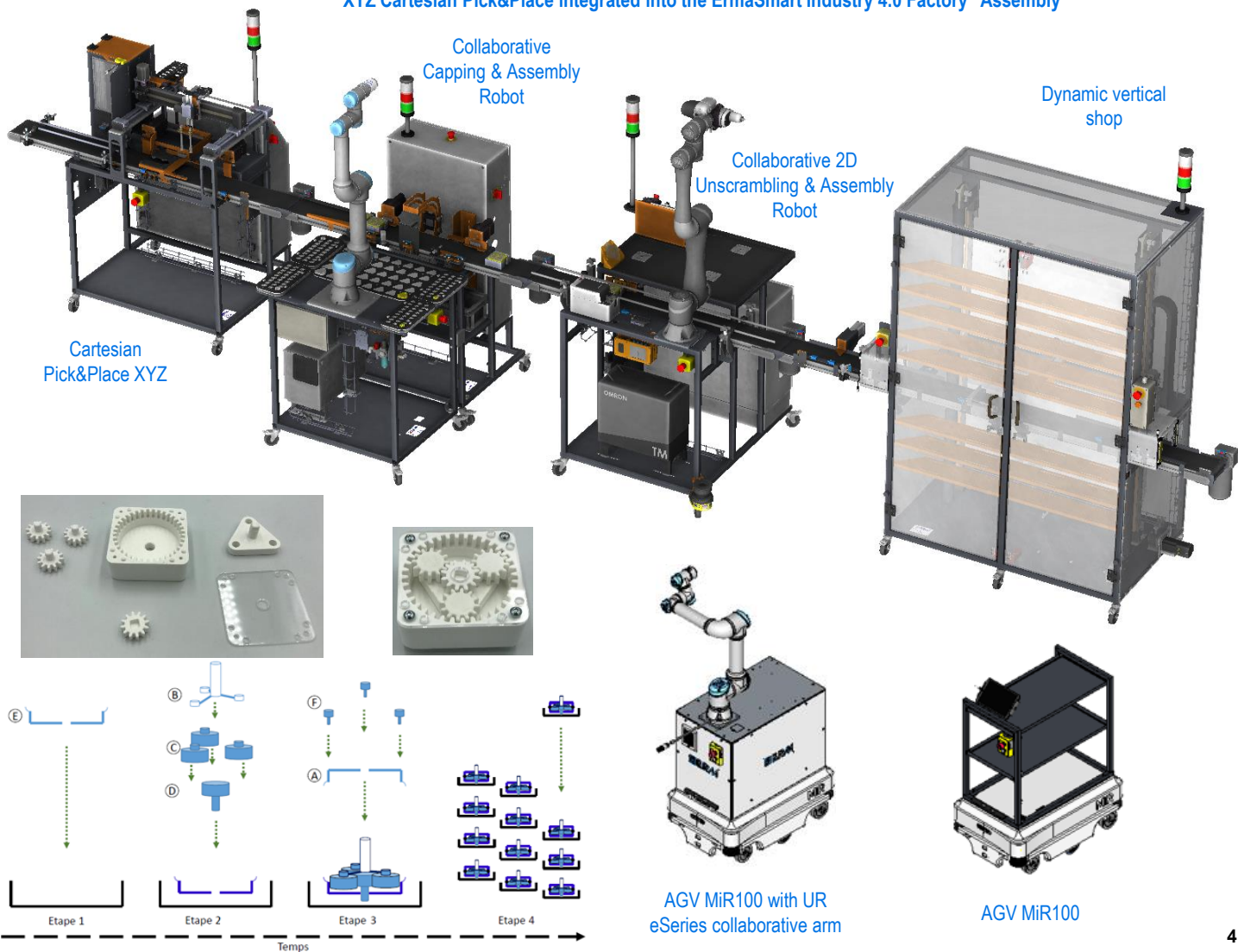



Educational activities

The XYZ Cartesian Pick&Place system allows for the following educational activities, among others:

✓ Electrical engineering

- **Discovery and handling of the system** (functional analysis and study of system technologies)
- **Control of the system's electrical quantities** (network, power supply, drive, XYZ axis controls, PLC, HMI and control circuit).
- **Commissioning and validation of the system operation** (of the different production modes)
- **Adjustment and parameterisation** of the installation components (three-phase asynchronous motor and its frequency converter, XYZ axis control)
- **Wiring of new sensors and actuators** in an **eco-responsible** way (improvement and/or replacement of an electrical component of the installation)
- **Programming of new cycles** of the PLC and the Human Machine Interface (TIA Portal software supplied).
- **Diagnosis of one or more malfunctions**
- **Use of digital tools and communication**

✓ Automation

- **Functional and structural analysis** of the system
- **Programming the XYZ Cartesian robot axis commands**
- **Programming of production cycles** (TIA Portal software delivered with the system)

- **Programming of the human machine interface** (TIA Portal software delivered with the system)

- Implementation of IO-Link sensors (Reassignment of inputs/outputs...) and IO-Link vacuum generator

✓ Production control

- **Production control** with choice of packaging method (in cartons or trays)
- **Change of production format,**
- **Traceability and logistics with RFID tag writing**
- **Development of operator support procedures**
- **Optimising production with digital 4.0 tools**

✓ Industrial maintenance

- **Preventive maintenance** (conveyors, suction, etc.)
- **Corrective maintenance** (fault diagnosis using the TIA PORTAL basic software delivered with the cell, rapid manufacture of 3D printing tools, etc.)
- **Improved maintenance** (addition of sensors on the conveyor, new format of boxes, trays,...)

✓ Mechanics

- Study of a robotic workstation, ergonomics, robot and actuator sizing...
- Design of 3D printed parts



References

XY10: Cartesian Pick&Place XYZ

XY12: Tools and components for the XYZ Cartesian Pick&Place assembly process

XY14: Mechanical module Cartesian axes XYZ

UC90 : Option: Fault box for electrical box, remotely configurable on a tablet (Not supplied)

UC50: MES Tulip, Visual Instructions & Production Indicator Monitoring, for the line manager - PC with Kepware communication server - Tulip Pro software in free Academic Version - "Light" supervision applications - MES applications developed by ERM Automatismes (Launching and monitoring of OFs, Rate monitoring, Calculation of key indicators such as TRS, Visual instructions for the line manager)

UC51: Option: Visual Instructions & Monitoring of Production Indicators on the Tulip open application environment and touch pad, for one machine

UC52: Option Visual instructions on Tulip open application environment and touch pad, for one machine

UC41: Siemens Remote Desk Option on iPad (Included)

IO01: Option: Electrical and pneumatic measurement sensors (IO-Link) for monitoring the power, flow and electrical and pneumatic consumption of a machine equipped with an IO-Link master and supervision and preventive maintenance software

JN-VUPro-XY10: XYZ digital 3D programmable Pick&Place twin on Virtual Universe Pro

VI20: Siemens Digital Twin Hardware Pack for programming the digital twin in the TIA Portal environment (S7-1200 PLC + additional I/O board + 230V-24V power supply)

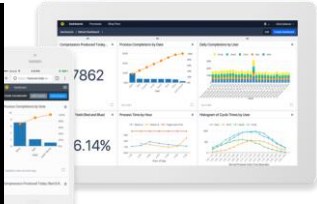
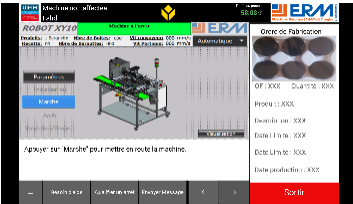

Electrical and pneumatic measurement sensors (IO-Link) for monitoring the power, flow and electrical and pneumatic consumption of a machine equipped with an IO-Link master (Ref: IO01)

Option Visual instructions & Monitoring of production indicators on the Tulip open application environment and touch tablet, for a (Ref: UC51)

Diota" Augmented Reality Scenario available



From the CAD/PLM tool (Solidworks Composer) to the industrial maintenance RA scenario job card
DF10: Industrial augmented reality solution DIOTA Tablet

